



PRESSURE SWITCH

DIMENSIONS

MILLIMETERS(INCHES)

DNA Series Pressure Switches

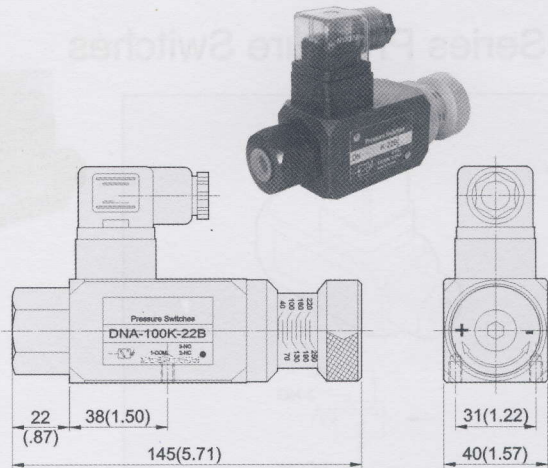
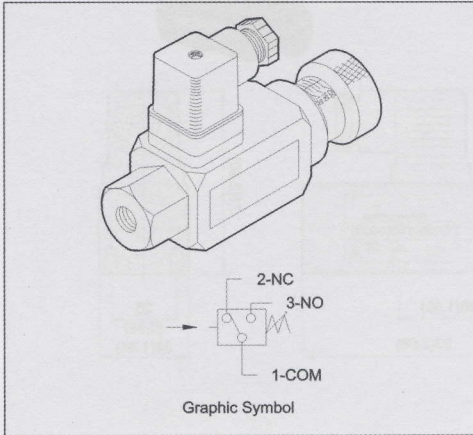

Ordering Code

DNA - 100K - 22B

① ② ③

- ① Series DNA-
Direct read-out,
Standard type.
- ② Pressure Adj. Range

Model	Pres Adj. Range bar	Surge Pres. bar	Weight kg
040K	6~ 40	150	1.0
100K	15~100	250	1.0
250K	40~250	300	1.0
360K	50~360	400	1.0

- ③ Design Number
22B:1/4"PT(Rc)
22B80:1/4"PF(2G)
22B90:1/4"NPT

Hysteresis Diagrammes

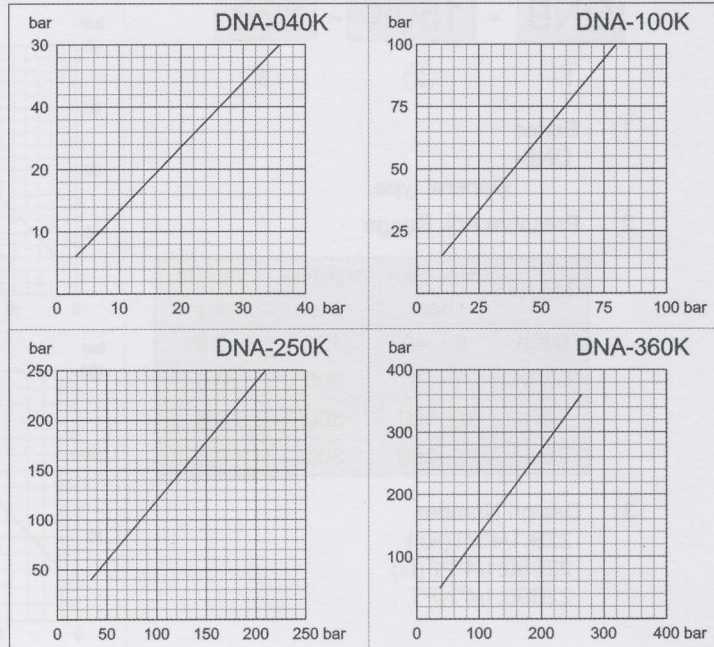

Schematic Cross-Section

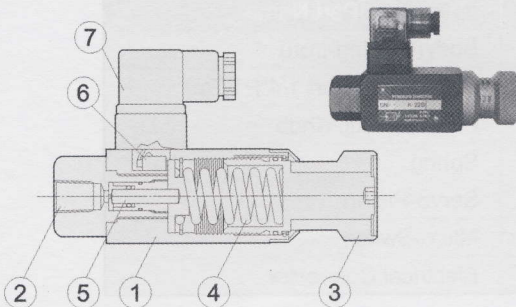

No.	Part Name
1	Body(Casting-Iron)
2	Connection Port 1/4"PT(Rc)
3	Pressure Adj. Knob
4	Spring
5	Servo-Piston
6	Micro-Switch
7	Electrical Connector

DNB Series Pressure Switches

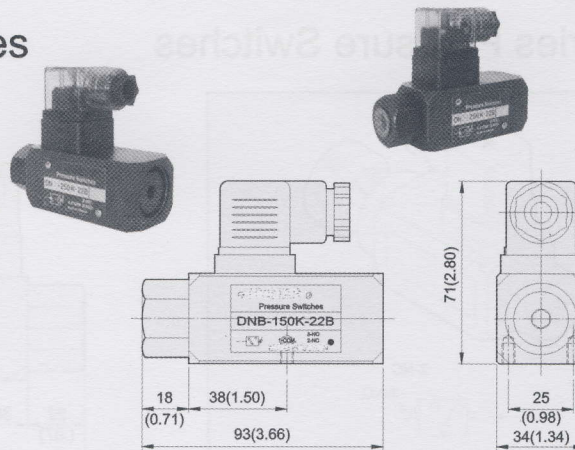
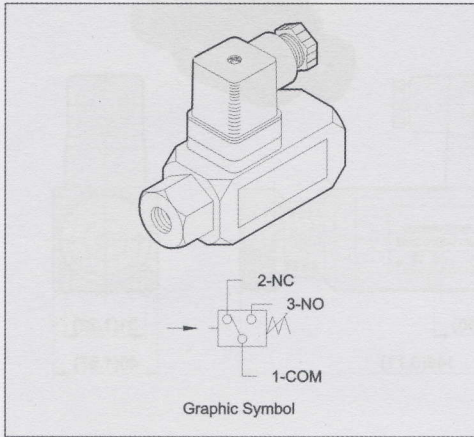

Ordering Code

DNB - 150K - 22B

- ① Series DNB- General type.
- ② Pressure Adj. Range
- ③ Design Number

Model	Pres Adj. Range	Surge Pres.	Weight
	bar	bar	kg
040K	6~ 40	150	0.6
070K	5~ 70	200	0.6
150K	30~150	300	0.6
250K	40~250	300	0.6

- ③ Design Number
22B:1/4"PT(Rc)
22B80:1/4"PF(G)
22B90:1/4"NPT

Hysteresis Diagrammes

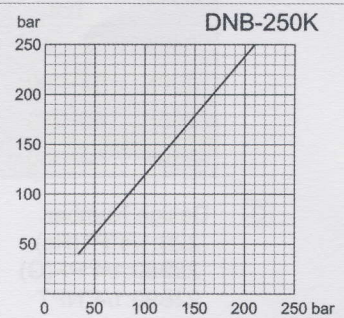
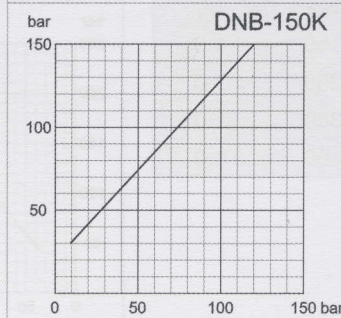
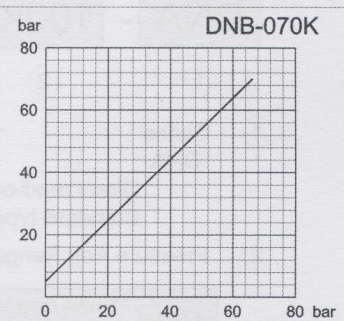
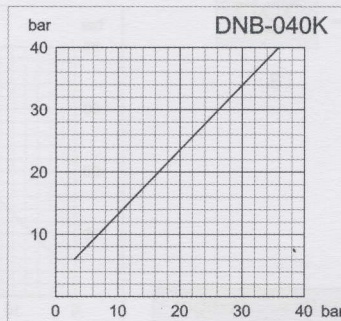

Schematic Cross-Section

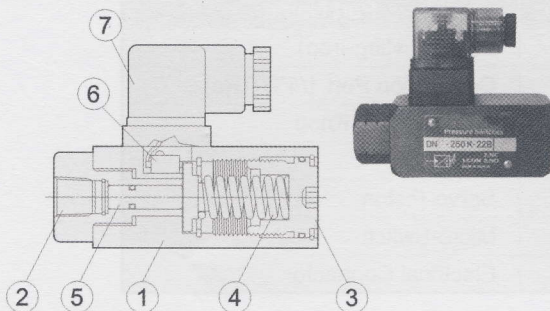

No.	Part Name
1	Body(Casting-Iron)
2	Connection Port 1/4"PT(Rc)
3	Pressure Adj. Knob
4	Spring
5	Servo-Piston
6	Micro-Switch
7	Electrical Connector



PRESSURE SWITCH

DIMENSIONS

MILLIMETERS(INCHES)

DNC Series Pressure Switches

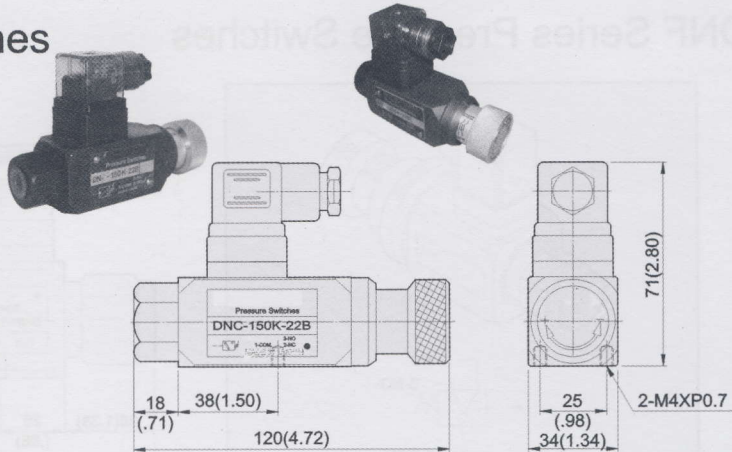
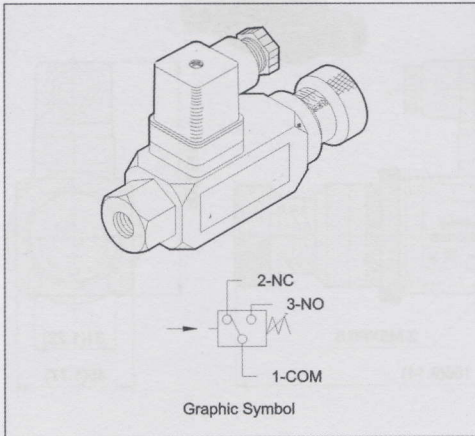

Ordering Code

DNC - 150K - 22B

① ② ③

- ① Series
DNC-
General type.
- ② Pressure Adj. Range

Model	Pres Adj. Range	Surge Pres.	Weight
	bar	bar	kg
040K	6~ 40	150	0.6
070K	5~ 70	200	0.6
150K	30~150	300	0.6
250K	40~250	300	0.6

- ③ Design Number
22B:1/4"PT(Rc)
22B80:1/4"PF(G)
22B90:1/4"NPT

Hysteresis Diagrammes

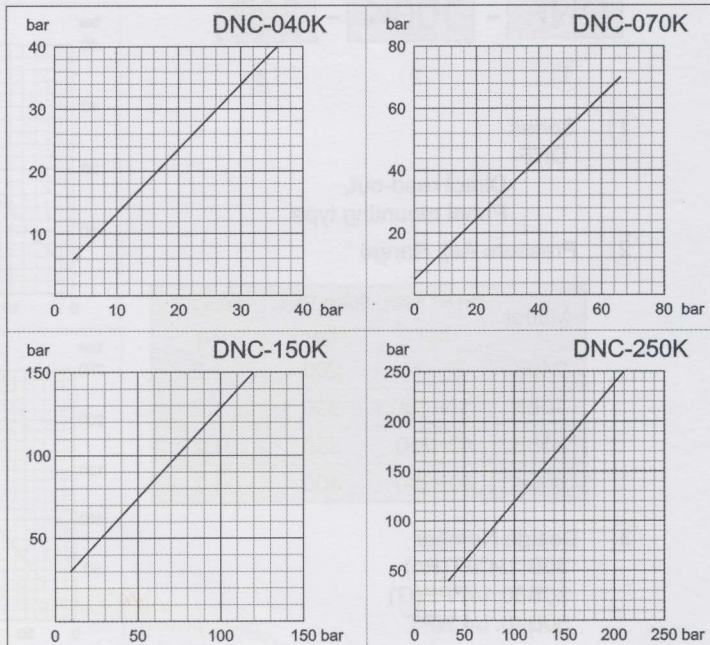

Schematic Cross-Section

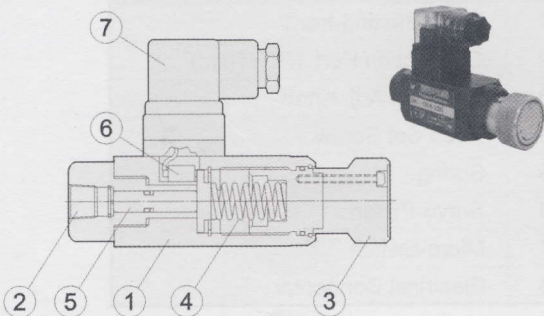

No.	Part Name
1	Body(Casting-Iron)
2	Connection Port 1/4"PT(Rc)
3	Pressure Adj. Knob
4	Spring
5	Servo-Piston
6	Micro-Switch
7	Electrical Connector

DNF Series Pressure Switches

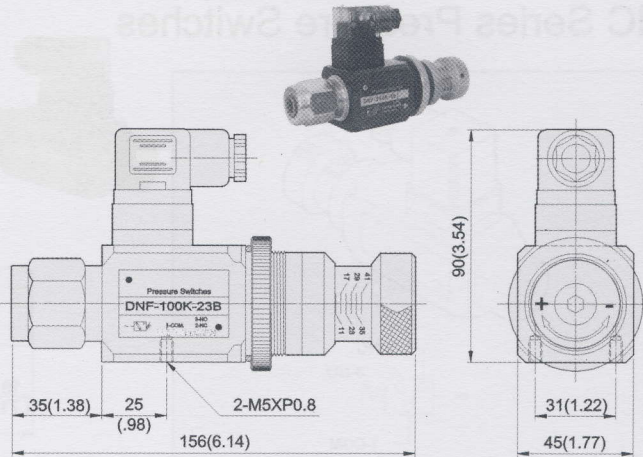
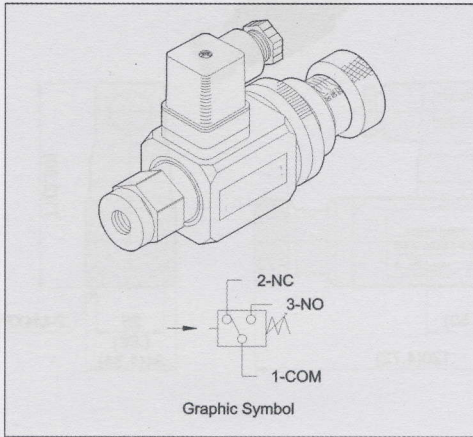

Ordering Code

DNF - 100K - 30B

- ① Series
DNF-
Direct read-out,
Panel mounting type.
- ② Pressure Adj. Range

Model	Pres Adj. Range bar	Surge Pres. bar	Weight kg
040K	6~ 40	200	1.2
100K	15~100	350	1.2
250K	40~250	350	1.2
360K	50~360	400	1.2

- ③ Design Number
30B:1/4"PT(Rc)
30B80:1/4"PF(G)
30B90:1/4"NPT

Hysteresis Diagrammes

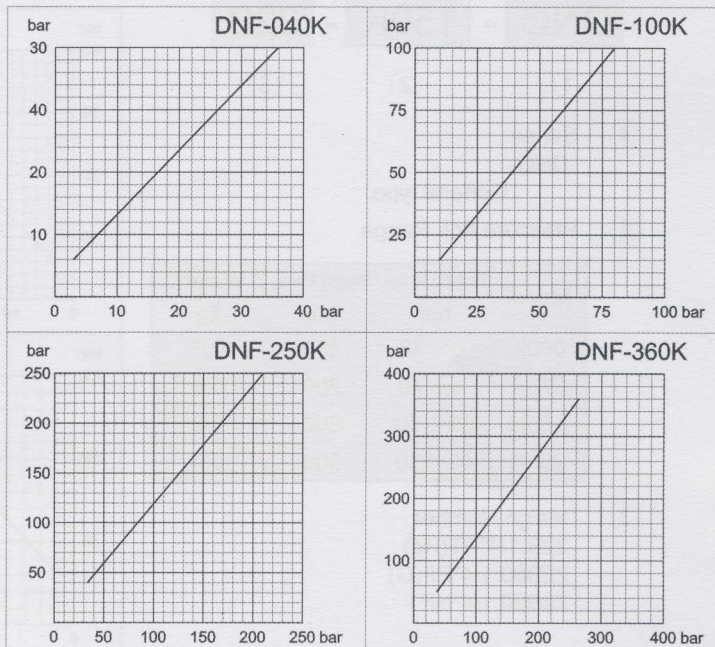

Schematic Cross-Section

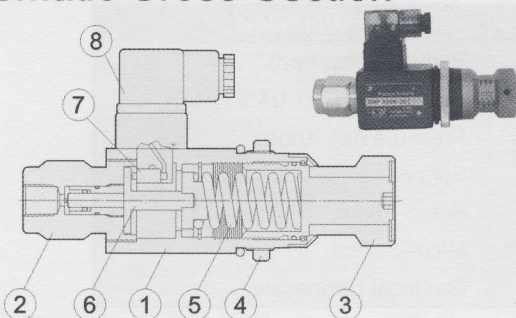

No.	Description
1	Body(Casting-Iron)
2	Connection Port 1/4"PT(Rc)
3	Pressure Adj. Knob
4	Knob Set Screw
5	Spring
6	Servo-Piston
7	Micro-Switch
8	Electrical Connector